

## BODY LUBRICATION

The movable mechanical hardware parts of a Fisher Body are lubricated at the factory to ensure proper and quiet operation. Because of the frequent use of some parts such as door locks and door lock strikers, it is important that the readily accessible parts be lubricated at least twice a year. Other body parts should be lubricated whenever access to the parts is available.

### BODY PARTS WHICH SHOULD BE LUBRICATED TWICE A YEAR

#### INSTRUMENT PANEL COMPARTMENT DOOR HINGE

**2562, 2562DF, 2563F, 2564DF**

Apply one (1) or two (2) drops of dripless oil to male and female hinge straps at locations indicated at one (1) in illustration. Wipe off excess lubricant. →

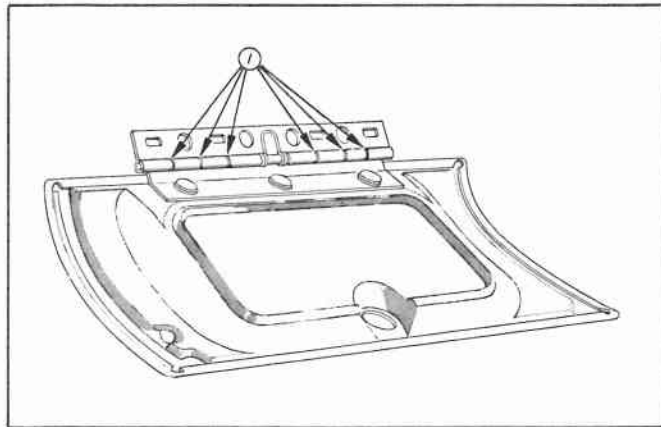
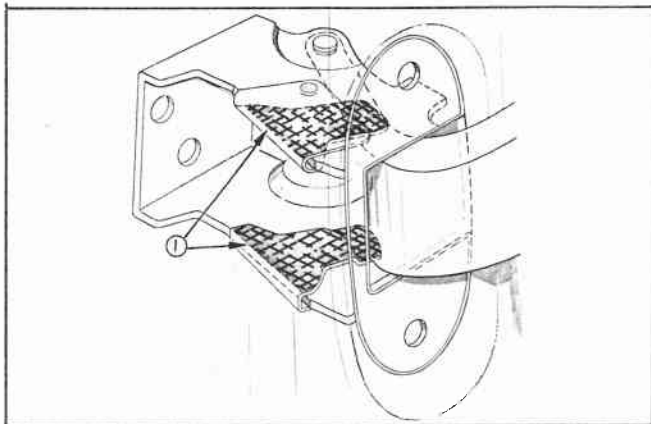

#### FRONT DOOR HINGE HOLD-OPEN CLIPS

**2562, 2562DF, 2563F, 2564DF**

← Wipe off dirt and apply light coat of #630 AA Lubriplate or its equivalent to clips indicated at one (1) in illustration.

#### DOOR JAMB SWITCH

**2562, 2562DF, 2563F, 2564DF**

Apply light coat of #630 AA Lubriplate or its equivalent to surface of switch plunger indicated at one (1) in illustration. →

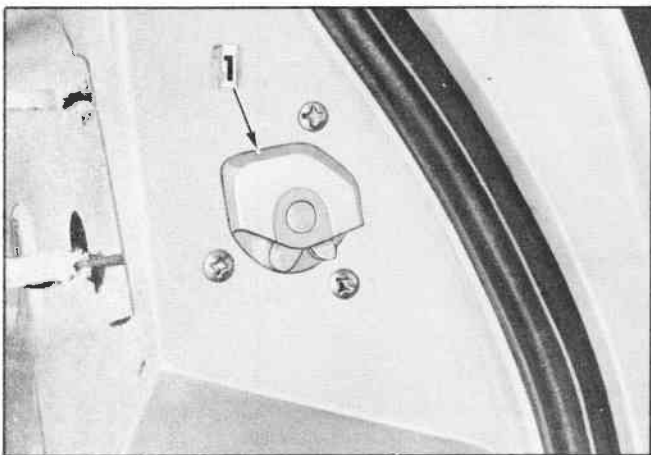

#### DOOR LOCK STRIKER

**2562, 2562DF, 2563F, 2564DF**

Wipe off dirt and apply thin coat of stick type lubricant to top surface of striker teeth indicated at one (1) in illustration. After lubrication, close door several times and remove excess lubricant along side edge of teeth. →

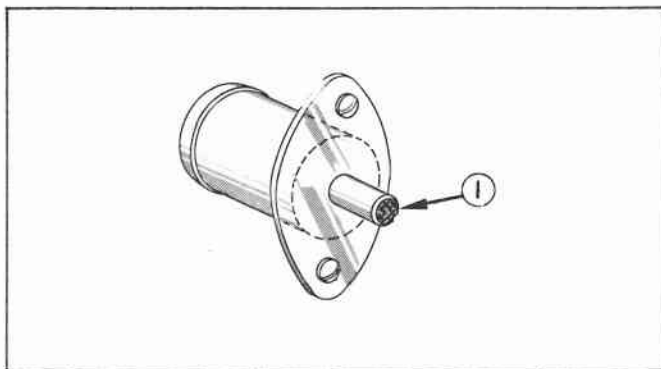

#### DOOR LOCK

**2562, 2562DF, 2563F, 2564DF**

← Wipe off dirt and apply thin coat of stick type lubricant on surface of lock bolt housing indicated at one (1) in illustration. Wipe off excess lubricant.

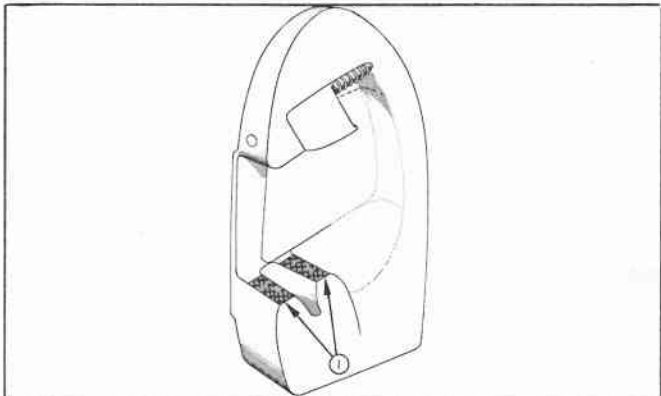

**REAR DOOR HINGE AND HOLD-OPEN ASSEMBLY**

**2562, 2562DF**

Wipe off dirt and apply one (1) or two (2) drops of mixture specified below to points indicated by arrows in illustration. Wipe off excess lubricant. Mixture is made up in a proportion of 1 lb. of #630 AA Lubriplate to 2 quarts of mineral spirits.

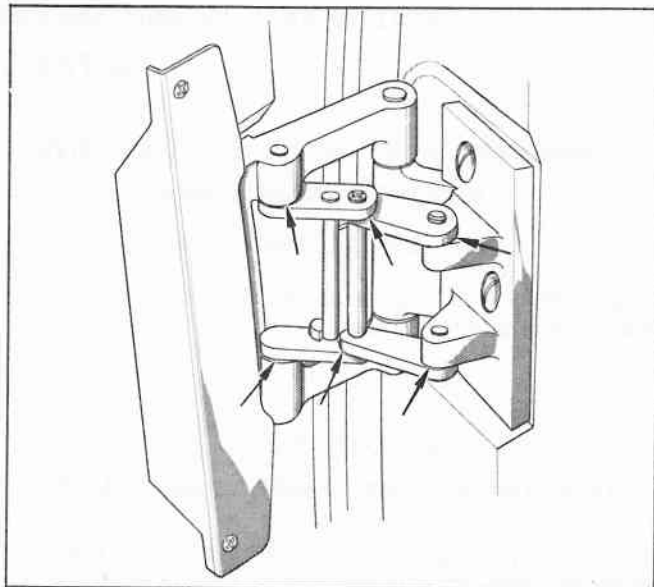
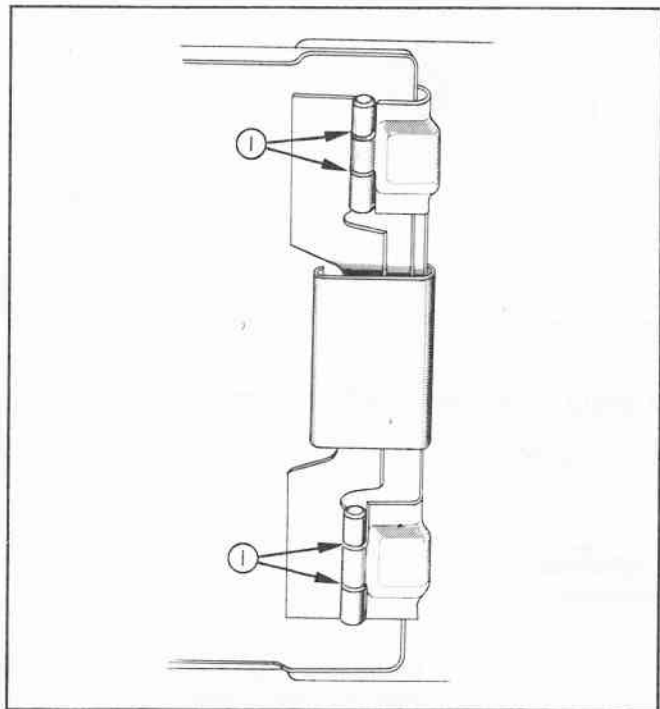

**GAS TANK FILLER DOOR**

**2562, 2562DF, 2563F, 2564DF**

Apply one (1) or two (2) drops of dripless oil to hinge points indicated at one (1) in illustration. Wipe off excess lubricant.

**FRONT SEAT SIDE PANELS**

**2562, 2562DF, 2563F, 2564DF**

Apply light coat of stick type lubricant along upper edge of front seat side panel indicated at one (1) in section "B-B". Wipe off excess lubricant.

The panel should be lubricated twice a year, or whenever an objectionable noise due to friction between side panel and leather seat trim is present.

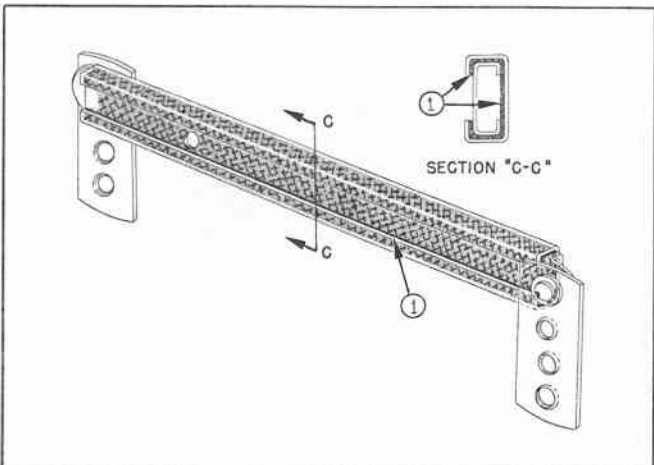
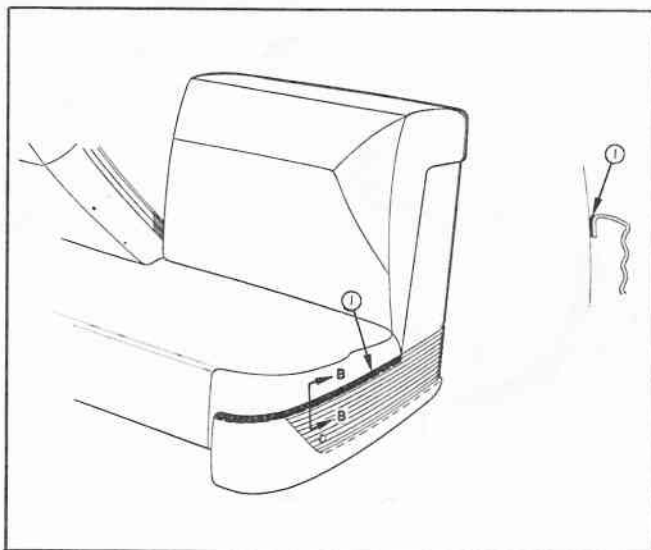

**LIFT GATE SUPPORT ASSEMBLY**

**2562, 2562DF, 2563F, 2564DF**

Wipe off dirt and apply #630 AA Lubriplate or its equivalent over inside surface of support outer channel indicated at one (1) in Section "C-C".

## BODY PARTS WHICH SHOULD BE LUBRICATED WHEN ACCESS TO PARTS IS AVAILABLE

### WINDSHIELD WIPER MOTOR AUXILIARY DRIVE AND WIPER TRANSMISSION

**2562, 2562DF, 2563F, 2564DF**

Apply #630 AA Lubriplate or its equivalent to locations indicated at one (1) in illustration. →

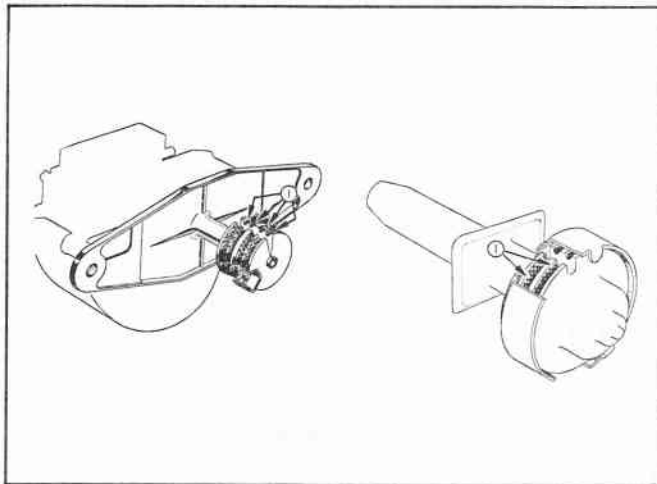

### DOOR LOCK PARTS

**1955 PONTIAC 2562, 2562DF, 2563F, 2564DF**

Lubricate moving parts of door lock with lubricant mixture made up in proportion of 1 lb. of #630 AA Lubriplate to 2 quarts of mineral spirits.

### DOOR AND REAR QUARTER WINDOW REGULATOR AND CAM CHANNELS

**2562, 2562DF, 2563F, 2564DF**

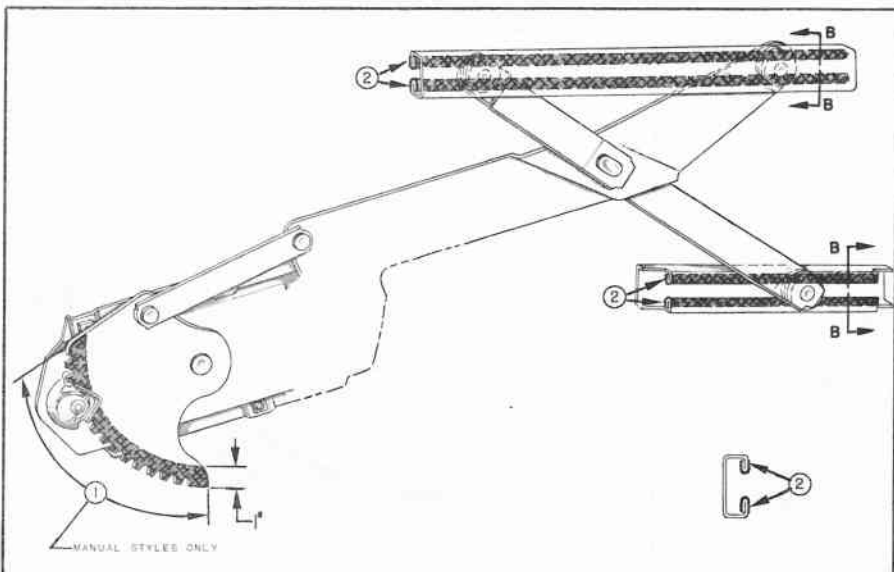

← On manual regulators, apply coat of #630 AA Lubriplate or its equivalent to rack portion of regulator sector as indicated at one (1) in illustration. On all regulators, apply #630 AA Lubriplate or its equivalent to channel portion of cam as indicated at two (2).

### LIFT GATE HINGE ASSEMBLY

**2562, 2562DF, 2563F**

Wipe off dirt and apply #630 AA Lubriplate or its equivalent to hinge areas indicated by arrows. →

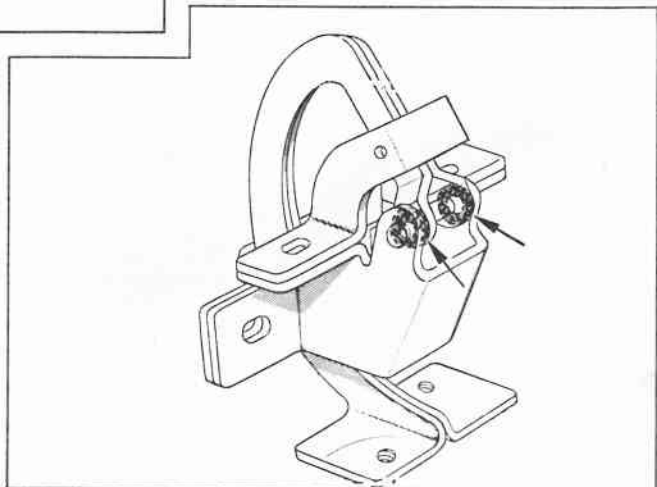

**LIFT GATE HINGE TORQUE RODS**

**2564DF**

Wipe off dirt and apply #630 AA Lubriplate or its equivalent to hinge areas indicated by arrows.

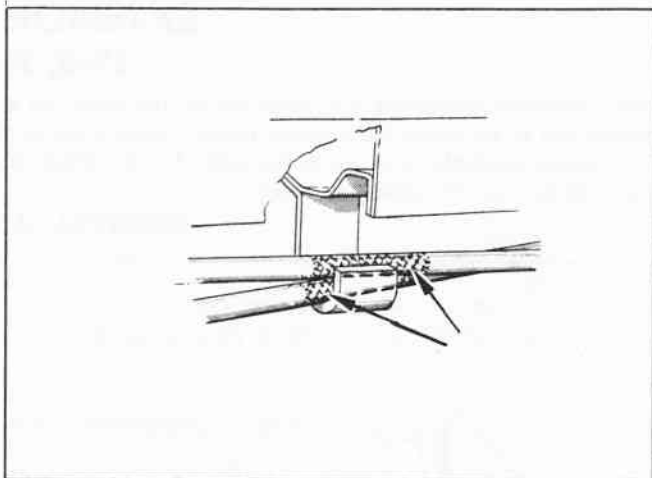
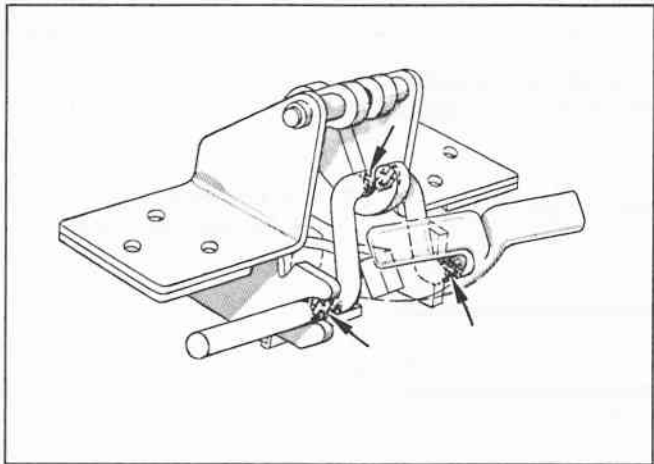

**LIFT GATE HINGE ASSEMBLY**

**2564DF**

Wipe off dirt and apply #630 AA Lubriplate or its equivalent to hinge areas indicated by arrows.



**NOTES**

Lined area for notes.