

TAIL GATE ASSEMBLY

1062F, 1062DF, 1063F, 1064DF, 1263F, 2263F 2562, 2562DF, 2563F, 2564DF

The tail gate is secured to the body by two (2) hinges located at the lower edge of the tail gate. Support cables with reel assemblies located between the inner and outer quarter panels support the tail gate when it is in the open position.

REMOVAL

Either of the following two methods may be used to remove the tail gate from the body.

- a. Tail gate and hinges may be removed as an assembly from the body.
- b. Tail gate may be removed from the hinge straps.

1. Lower tail gate and raise lift gate.
2. Suitably support tail gate in open position to prevent damage to tail gate outer panel.
3. At each side of tail gate remove two (2) screws "A" securing tail gate support retaining plate, then allow the reel to draw cable with support and retaining plate, until retaining plate contacts cable guide on body lock pillar.
4. If removing tail gate from hinge straps, carefully pry hinge escutcheons from tail gate outer panel. Loosen tail gate weatherstrips at hinge areas sufficiently to remove both hinge cover plates and remove hinge cover plates.
5. If removing tail gate and hinges, remove both cover plates from body.
6. Clean off excess sealer from edge of both hinge

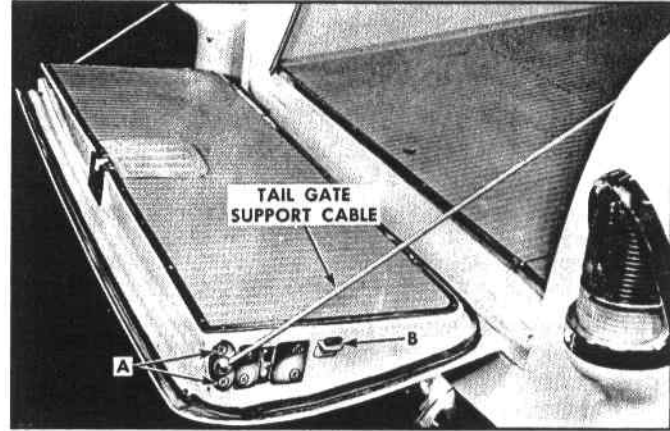

straps at body or tail gate, then scribe location of hinge straps.

7. Remove hinge attaching screws and remove tail gate from body.

INSTALLATION

1. Apply heavy-bodied sealer to contacting surface of both hinge straps as indicated at one (1).
2. With aid of helper lift tail gate into position. Install attaching screws loosely, then align hinge straps within scribe marks and tighten screws. Check tail gate for alignment.
3. Before hinge cover plates are installed, tail gate hinges must be sealed with medium-bodied sealer or caulking compound as outlined below:
 - a. Apply body caulking compound in corners of hinge depression as indicated at one (1).
 - b. Apply continuous ribbon of medium-bodied sealer along outside surface of cover plate flange as indicated at two (2) and along inside surface of cover plate as indicated at three (3). Seals should connect with seal applied in corners of hinge depression. Seal cover plates on tail gate side in similar manner.
4. Install hinge cover plates and support cable retaining plates. Clean off excess sealer.

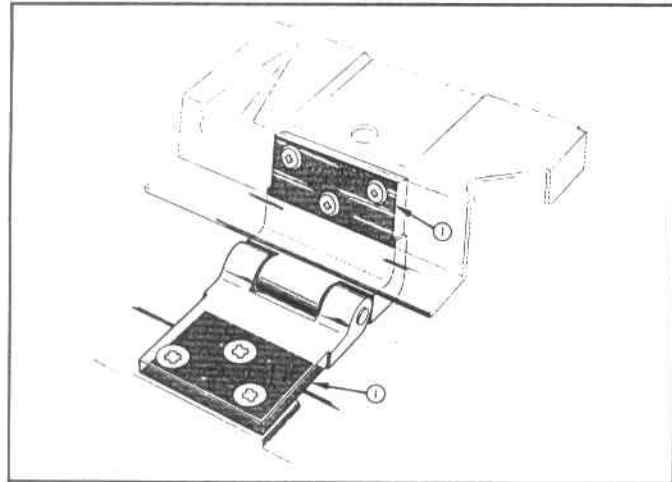

ADJUSTMENTS

1. Remove both tail gate lock strikers.
2. To adjust tail gate sideways in the opening or to adjust bottom of tail gate forward or rearward, remove hinge cover plates and loosen hinge-to-body attaching screws. Adjust tail gate as required, then tighten hinge attaching screws. Reseal and install cover plates.
3. Reinstall tail gate lock strikers.
4. To adjust upper portion of tail gate forward or rearward, loosen screws securing both tail gate lock strikers. Adjust strikers as required then tighten screws. The strikers may also be adjusted up or down. See "Tail Gate Lock Striker" for additional adjustments.
5. The tail gate bumper stop support "B" may be adjusted fore or aft. The bumper should contact rabbet on body lock pillar when tail gate is closed.

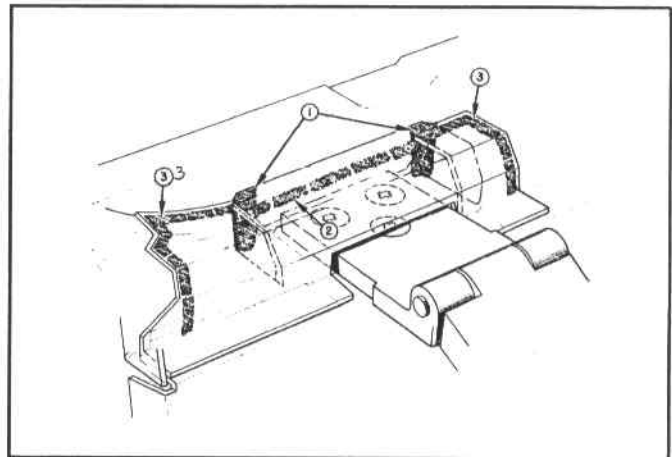

TAIL GATE LOCK OUTSIDE HANDLE

1062F, 1062DF, 1063F, 1263F, 2263F
2562, 2562DF, 2563F

The tee-type handle is located at the upper center of the tail gate outer panel and is secured by two (2) screws. The handle operates as follows: When the handle is turned, the handle shaft actuates the remote control levers to which the connecting rods are attached. The connecting rodstrip the lock lever at each side of the tail gate, thereby disengaging the lock bolt from the striker.

REMOVAL AND INSTALLATION

1. Lower tail gate and remove access hole cover "A".
2. Remove remote control assembly attaching screws, then lift remote control and disengage it from connecting rods.
3. Remove two (2) screws securing handle to tail gate outer panel and remove handle and gasket from tail gate.
4. To install, reverse removal procedures. Be sure to reinstall clips at ends of remote control connecting rods.

TAIL GATE LOCK

1062F, 1062DF, 1063F, 1064DF, 1263F, 2263F
2562, 2562DF, 2563F, 2564DF

REMOVAL AND INSTALLATION

1. Remove access hole cover "A" and remove remote control assembly.
2. Remove four (4) screws "B" securing lock, then remove lock and remote control connecting rod from tail gate.
3. To install, reverse removal procedure. Be sure to install clips at ends of remote control connecting rods..

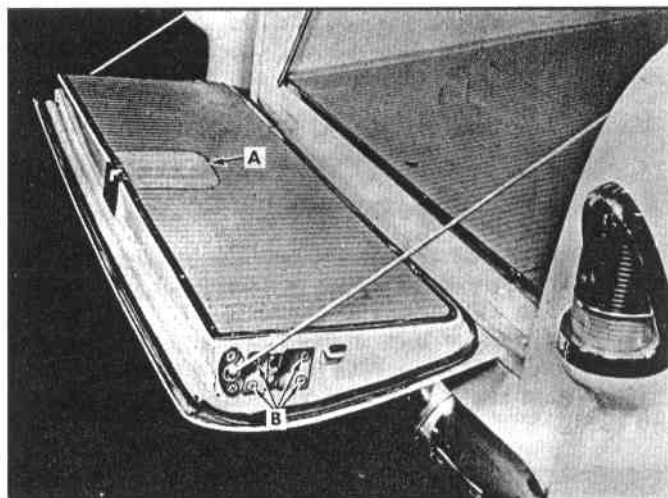

TAIL GATE LOCK STRIKER

1062F, 1062DF, 1063F, 1064DF, 1263F, 2263F
2562, 2562DF, 2563F, 2564DF

REMOVAL AND INSTALLATION

1. Open tail gate and with pencil scribe the location of striker on body pillar.
2. Remove four (4) screws "A" and remove striker and adjusting plates from body pillar.
3. To install, place striker and adjusting plates within scribe marks on body pillar and install screws.

ADJUSTMENTS

1. To adjust tail gate lock striker up or down, or forward or rearward, loosen striker attaching screws "A", locate striker as required, then tighten screws.
2. To check engagement of tail gate lock with striker, proceed as follows:
 - a. Insert small quantity of modeling clay or its equivalent to bottom of lock bolt slot as shown in inset of illustration.
 - b. Close tail gate with moderate slam.
 - c. Open tail gate and measure distance "X" indicated in illustration. Distance "X" should be 3/16" to 5/16". If distance is greater, install emergency spacer between striker and adjusting plates to obtain proper engagement.

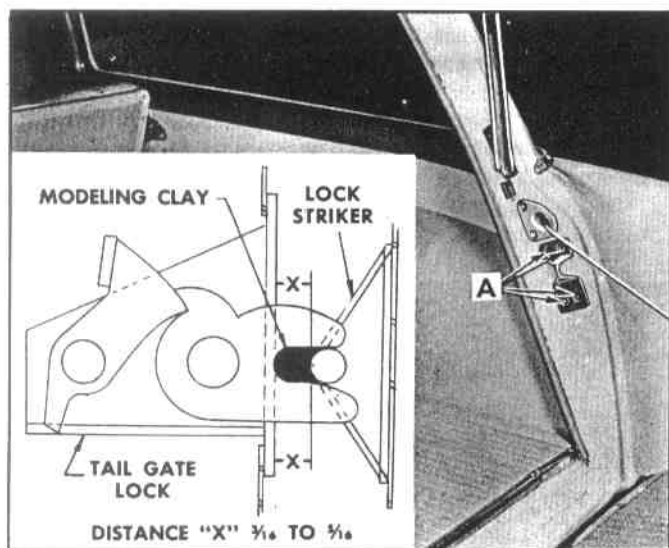

TAIL GATE OUTSIDE HANDLE

1064DF, 2564DF

The stationary-type, vertical handle, shown in the illustration, is located on the tail gate outer panel directly below the push button, and is secured by two (2) screws. To remove handle from the tail gate, it is necessary to remove tail gate access hole cover and remote control assembly to gain access to the handle attaching screws.

REMOVAL AND INSTALLATION

1. Remove tail gate access hole cover.
2. Remove four (4) screws securing remote control assembly to inner panel and push button housing, then disengage remote control assembly from connecting rods and remove from tail gate.
3. Working through access hole, remove two (2) screws securing tail gate handle and remove handle.
4. To install, reverse removal procedure. Be sure to install clip at ends of remote control connecting rods.

TAIL GATE LOCK REMOTE AND PUSH BUTTON CONTROL ASSEMBLY

1064DF, 2564DF

The tail gate lock remote and push button control is located at the center of the tail gate. The assembly operates as follows: When the push button is depressed, the button shaft actuates the remote control levers to which the connecting rods are attached. The connecting rods trip the lock lever at each side of the tail gate, thereby disengaging the lock bolt from the lock striker. When the push button lock cylinder is rotated to the locked position with a key, the push button shaft by-passes the remote levers when the push button is depressed; since the levers are not actuated, the tail gate remains closed. The illustration shows the remote and push button control assembly removed from the tail gate.

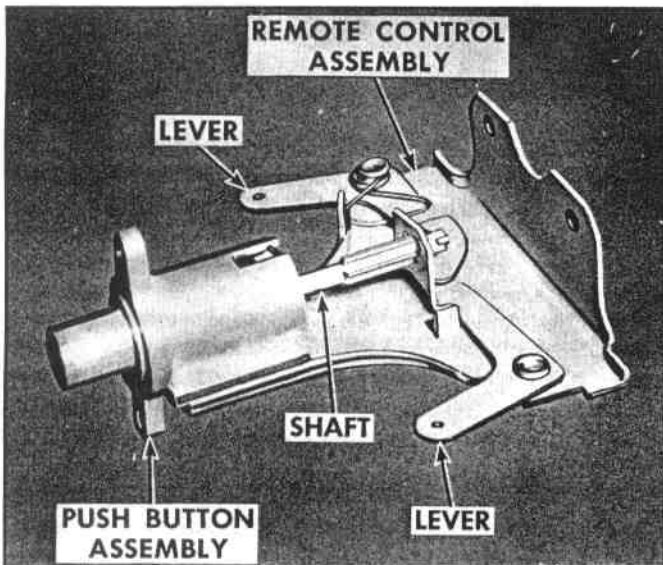
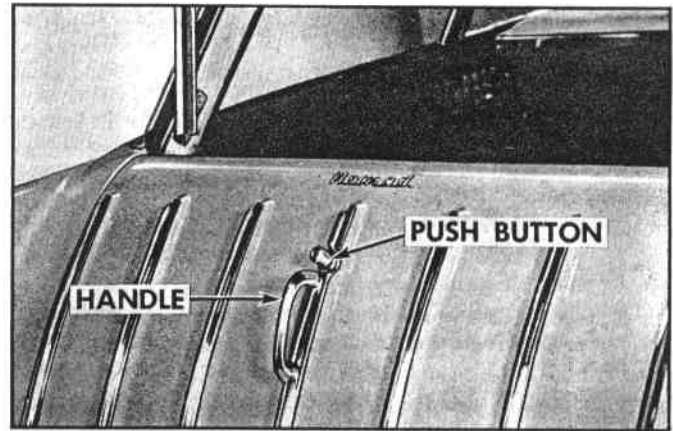

REMOVAL AND INSTALLATION

1. To remove remote control assembly, proceed as follows:
 - a. Remove tail gate access hole cover.
 - b. Remove screws securing control to inner panel and push button housing.
 - c. Disengage remote control from connecting rods and push button shaft and remove from tail gate.
2. To remove push button assembly, proceed as follows:
 - a. At tail gate outer panel, carefully pry off portion of tail gate outer panel center molding, located above tail gate handle, and remove screw securing push button housing.
 - b. Remove remote control assembly from push button housing and tail gate.
 - c. Remove screw securing upper edge of tail gate handle and lower edge of push button housing, then remove housing from tail gate.
3. To install, reverse removal procedure. Be sure to reinstall clips at ends of remote control connecting rods.

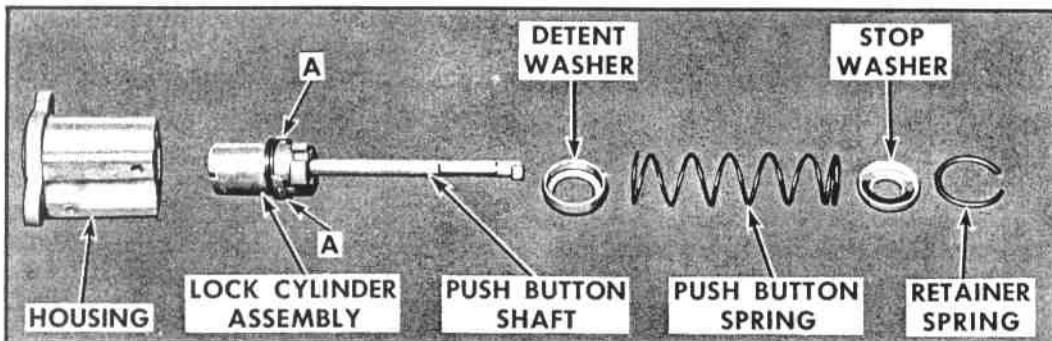

DISASSEMBLY AND ASSEMBLY OF PUSH BUTTON

1. Remove push button assembly from tail gate and remote control assembly.
2. With suitable tool, remove retaining spring from housing, then remove stop washer, spring, detent washer

- and lock cylinder with push button shaft from housing.
3. To disassemble lock cylinder assembly, bend open tabs "A" and disassemble cylinder as required.
4. To install, reverse removal procedure.

TAIL GATE SUPPORT CABLE

1062F, 1062DF, 1063F, 1064DF, 1263F, 2263F
2562, 2562DF, 2563F, 2564DF

One end of the cable is secured to the tail gate by a retainer the other end of the cable is secured to a steel tape which is part of a reel assembly installed between the rear quarter inner and outer panels. When the tail gate is lowered, the steel tape unwinds from the reel assembly until the end of the support cable contacts a cable stop. A coil spring, located on the cable between the clevis and cable stop, provides a cushion action for the tail gate when it is in a fully lowered position. When the tail gate is closed, the steel tape winds up in the reel and draws the cable in between the quarter inner and outer panels.

REMOVAL AND INSTALLATION

1. Lower tail gate and raise lift gate.
2. Suitably support tail gate assembly to prevent damage to outer panel.
3. If the right tail gate support cable is affected, remove the right tail light assembly. Access to the left cable stop and ends of the left support cable and steel tape can be gained through the gas tank filler door opening.
4. Disengage support cable from cable stop. Remove cotter pin and clevis pin from ends of cable and steel tape, then with a strong cord or wire, tie end of tape to stationary body part to prevent tape from winding up into the reel.
5. Remove cable retaining plate screws "A" and retainer from tail gate. Pull cable through cable guide in body lock pillar and remove from body.
6. To install, reverse removal procedure. Be sure coil spring on cable is located between cable stop and clevis.

TAIL GATE REEL ASSEMBLY

1062F, 1062DF, 1063F, 1064DF, 1263F, 2263F
2562, 2562DF, 2563F, 2564DF

REMOVAL AND INSTALLATION

1. Lower tail gate and raise lift gate, then suitably support tail gate to prevent damage to outer panel.
2. If the right reel assembly is affected, remove right tail light assembly from body. Access to the left cable stop can be gained through the gas tank filler door opening.
3. Remove support retaining plate screws "A" and retainer from tail gate. Pull cable through cable guide in

TAIL GATE WEATHERSTRIP

1062F, 1062DF, 1063F, 1064DF, 1263F, 2263F
2562, 2562DF, 2563F, 2564DF

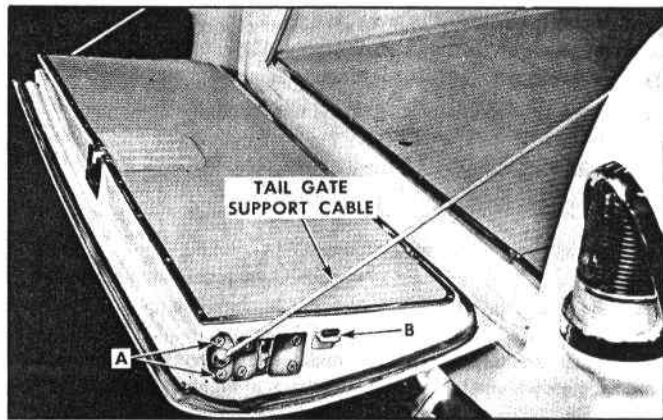
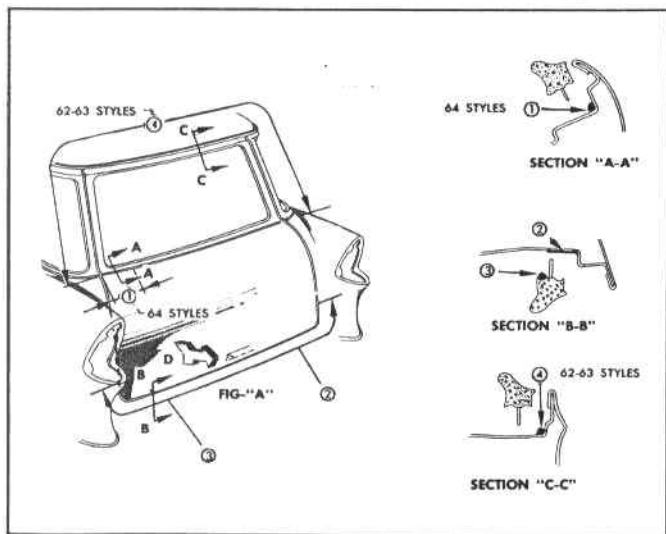

body lock pillar and disengage from cable stop.

4. Inside of body, remove rear quarter window rear garnish molding and side panel rear. On 1064DF-2564DF styles, remove side panel rear and loosen side panel front sufficiently to gain access to the reel assembly front access hole. NOTE: On 1064DF-2564DF styles, a front and rear access hole is provided for removal and installation of the cable and reel.
5. Remove four (4) screws securing tail gate reel cover and support to quarter panel, then pull cover and reel assembly into body. On 1064DF-2564DF styles, remove cable and reel rear access hole cover.
6. To remove reel from cable, remove cotter pin and clevis pin from ends of cable and reel.
7. To install, reverse removal procedure. Seal inner panel as specified in "Rear Quarter Inner Panel Sealing".

The mechanically-retained tail gate weatherstrip consists of a one-piece weatherstrip with an integral wire insert. The weatherstrip is secured to the tail gate by clips which are formed from the wire insert and snapped into holes around the perimeter of the tail gate. In addition, the weatherstrip is cemented along the bottom of the tail gate, and secured by two (2) screws at each upper corner of the tail gate.

REMOVAL

1. Remove two (2) screws at each upper corner of tail gate.
2. Using mechanically-retained weatherstrip inserting tool or other suitable tool, carefully position tip of tool under weatherstrip at each clip location and snap clip out of hole. NOTE: At cemented sections of weatherstrip, carefully break cement bond at same time that weatherstrip retaining clip is being snapped from hole.

INSTALLATION

(REFER TO ILLUSTRATION ON PREVIOUS PAGE)

1. Clean off old weatherstrip cement from tail gate.
2. On 1064DF and 2564DF styles, apply bead of weatherstrip cement in corner of rabbet as indicated at one (1) in Section "A-A". Seal is to extend four (4) inches inboard from each upper corner of tail gate.
3. Locate weatherstrip retaining tabs at upper corners of tail gate and using a mechanically-retained weatherstrip, inserting tool or other suitable tool, place "V" shaped tip of tool on loop of clip and push clip into hole until it is secured in position. Install weatherstrip along upper edge of gate only. NOTE: Do not use excessive force or strike tool when pushing clips into holes, as it

may distort the shape of the clip and result in improper weatherstrip retention. Illustration showing use of installing tool is located on page 17.

4. Apply approved weatherstrip cement following manufacturer's directions, along bottom and side of tail gate as indicated at two (2) in Figure "A" and Section "B-B".
5. Apply bead of approved weatherstrip cement along groove of tail gate weatherstrip, as indicated at three (3) in Section "B-B". Apply cement across bottom and radius of outer lower corners.
6. Cut ends of weatherstrip as required to form butt joint at bottom of tail gate, then install remaining weatherstrip attaching clips into holes in tail gate inner panel. Apply approved weatherstrip cement to ends of weatherstrip and form butt joint.

LIFT GATE ASSEMBLY

1062F; 1062DF, 1063F, 1263F, 2263F

2562, 2562DF, 2563F

The lift gate is secured to the back body opening roof rail by two (2) hinges. A telescoping support at each side of the lift gate locks the lift gate in either a horizontal position or at a position slightly above horizontal. For instructions on locking lift gate in either open position, see "Lift Gate Support".

REMOVAL AND INSTALLATION

Either of the following two methods may be used to remove the lift gate from the body.

- A. Lift gate may be removed from the hinge straps.
- B. Lift gate and hinges may be removed as an assembly from the body.

If removing lift gate from hinge straps proceed as follows:

1. Open lift gate to horizontal position.
2. At each side of lift gate, remove two (2) screws securing support to lift gate, then lower lift gate and remove lift gate window garnish molding.
3. Scribe location of hinge straps on lift gate. With helper supporting gate remove two (2) screws "A" and reinforcement from each hinge strap and remove lift gate from body.
4. To install, align hinges within scribe marks and reverse removal procedure.

If removing lift gate and hinges as an assembly from the body, proceed as follows:

1. Open lift gate to horizontal position.
2. At each side of lift gate, remove two (2) screws securing support to lift gate, then lower lift gate.
3. Inside of body, remove both lift gate hinge covers and finishing molding from above lift gate opening.
4. Detach headlining at hinge areas sufficiently to have access to hinge attaching screws "B".
5. Scribe location of hinges on body panel.
6. With helper supporting lift gate, remove hinge attaching screws "B" and remove lift gate.
7. To install, align hinges within scribe marks and reverse removal procedure. NOTE: See "Body Lubrication" for lubrication of hinges.

ADJUSTMENTS

1. To adjust top of lift gate forward or rearward, remove back window garnish molding and loosen hinge strap attaching screws. Position lift gate as required, then tighten screws and reinstall back window garnish molding.
2. To adjust lift gate sideways in the opening, remove hinge covers on inside of body and disengage headlining as required to loosen four attaching screws at both hinges. Position lift gate as required, then tighten screws and reinstall previously removed parts.

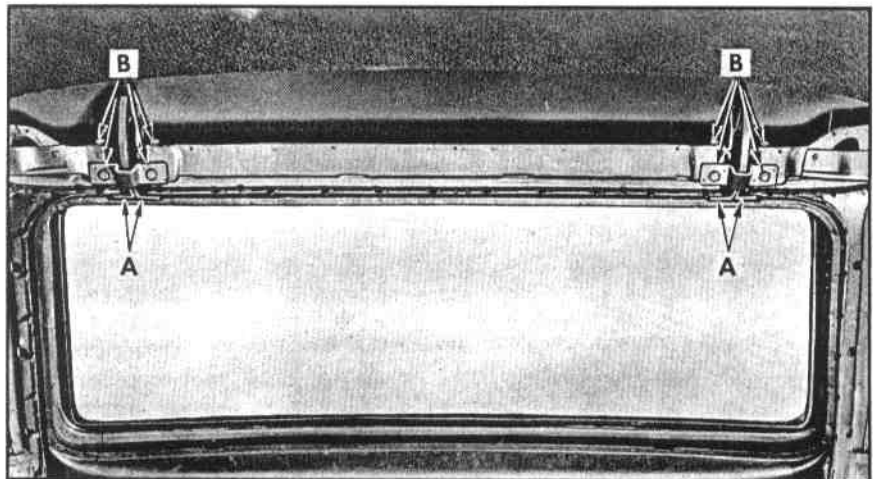

LIFT GATE WINDOW

1062F, 1062DF, 1063F, 1263F, 2263F
2562, 2562DF, 2563F

REMOVAL

1. Close lift gate and remove lift gate window garnish molding and retaining clips.
2. With suitable flat bladed tool, carefully break seal between rubber channel and metal panel completely around perimeter of window.
3. With palm of hand, carefully push glass with rubber channel toward front of car and remove glass with rubber channel from lift gate.

INSTALLATION

1. Clean off old sealer from around window opening and rubber channel.
2. Check window opening and rubber channel for irregularities, and correct if present.
3. Install rubber channel around glass, then apply weatherstrip cement between rubber and glass as indicated at one (1), around perimeter of glass.
4. Apply bead of medium-bodied sealer around perimeter of window opening in lift gate as indicated at two (2).
5. Install strong cord in rubber channel at outer lip around perimeter of lift gate window as shown at three (3), then tie and tape ends of cord to glass.

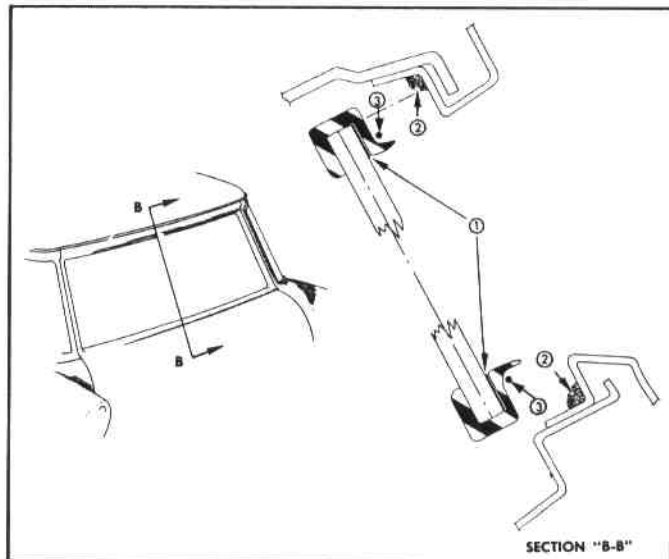

6. Install glass with rubber channel in opening, then pull ends of cord to seat lip of rubber channel on outer panel completely around window opening.
7. Install window retaining clips and garnish molding, then clean off excess sealer and cement.

LIFT GATE SUPPORTS

1062F, 1062DF, 1063F, 1064DF, 1263F, 2263F
2562, 2562DF, 2563F, 2564DF

A telescoping support which consist of an inner and outer channel is installed at the left and right side of the lift gate. The end of the inner channel is secured to the lift gate and the end of the lower channel is secured to the body pillar. The support is designed to lock the lift gate either in a horizontal position or in a position slightly above horizontal. To lock lift gate in full open position, lower tail gate, then, raise lift gate until support stop levers "A" are engaged in slots in outer channel. To unlock lift gate from open position, push stop knobs "A" rearward to disengage stop levers and lower lift gate.

To lock lift gate in horizontal position, lower tail gate and raise lift gate until stop knobs "A" are accessible. Push knobs forward to spring load stop levers, then lower gate until stop levers which are under spring tension engage in slots "B". The gate is unlocked in the same manner as outlined above. NOTE: The illustration shows the lift gate supports installed on a 1064DF style. The supports on the other styles are similar.

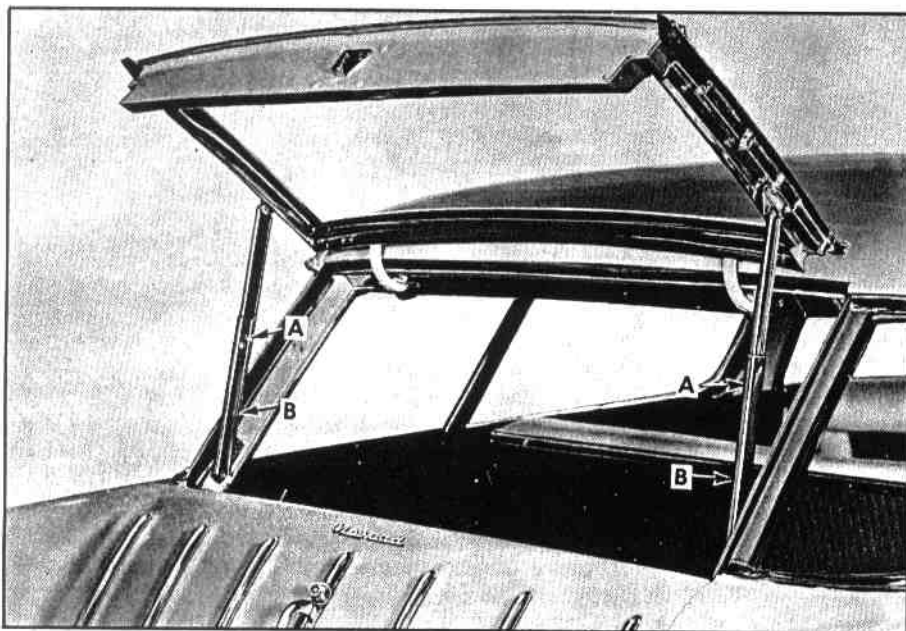

REMOVAL AND INSTALLATION

1. Lower tail gate and lock lift gate in open position.
2. Remove screws securing ends of support to lift gate and body, and remove support.
3. To install, reverse removal procedure. For lubrication of lift gate support, see "Body Lubrication" section.

LIFT GATE WEATHERSTRIPS

1062F, 1062DF, 1063F, 1263F, 2263F
2562, 2562DF, 2563F

The mechanically retained lift gate weatherstrip consists of a one-piece weatherstrip with an integral wire insert. The weatherstrip is secured to the lift gate by clips which are formed from the wire insert and snapped into holes around the top and sides of the lift gate. In addition the weatherstrip is secured in place by two (2) screws at each lower corner.

REMOVAL AND INSTALLATION

The basic steps of weatherstrip removal and installation are outlined in "Tail Gate Weatherstrip". To seal along top and side of lift gate weatherstrip apply bead of approved weatherstrip cement as indicated at four (4) in Section "C-C" in illustration on page 49.

LIFT GATE ASSEMBLY

1064DF, 2564DF

The lift gate frame assembly consists of a die cast lift gate window outer frame, right and left side inner frame, and lower inner frame. The assembly is secured to the body roof rail by two (2) hinges which incorporate torque rods to assist in raising the gate. A telescoping support at each side of the lift gate, locks the lift gate open in either a horizontal position, or a position slightly above horizontal. For instructions on locking lift gate in either open position, see "Lift Gate Support". For instructions on disassembling lift gate frame, see "Lift Gate Window".

REMOVAL AND INSTALLATION

1. Lock lift gate in open position.
2. With helper supporting gate in open position, remove three (3) of the four (4) screws securing gate to hinges at "A".
3. Remove screws securing right and left supports to lift gate, then removing remaining hinge attaching screw from each hinge strap and carefully remove lift gate. Place gate on covered bench.
4. To install, align hinges within scribe marks and reverse removal procedure.

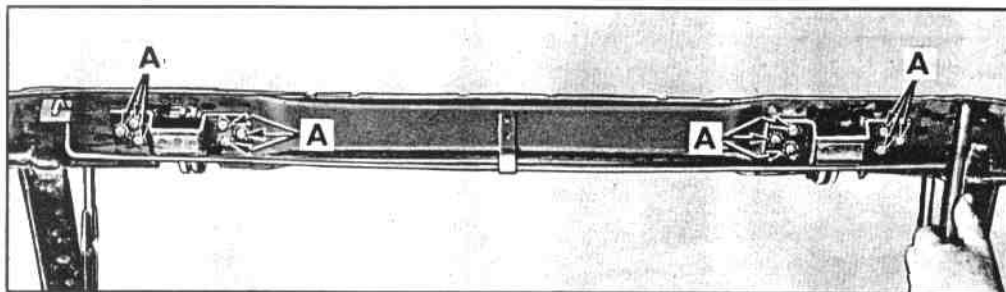
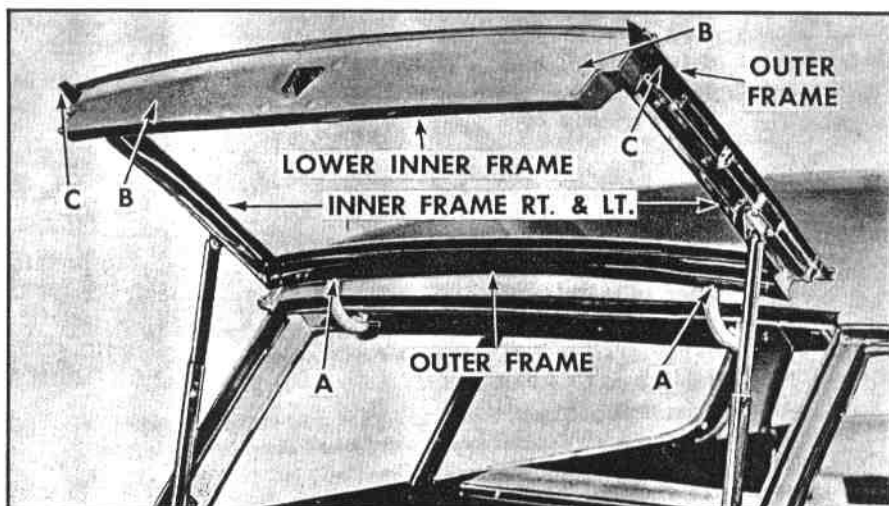

ADJUSTMENTS

1. To adjust lift gate assembly up or down, or side-ways, proceed as follows:
 - a. On inside of body, remove lift gate opening upper finishing molding, and detach headlining from trim sticks along length of lift gate opening.
 - b. Remove metal covers along roof rail to expose hinge attaching screws "A".
 - c. Scribe location of hinges and loosen screws "A". Adjust lift gate as required, then tighten attaching screws.
 - d. Reinstall previously removed parts.
2. To adjust closed position of lift gate upper edge forward, perform steps (a) and (b) outlined directly opposite, then loosen hinge attaching screws "A" and install emergency spacers between hinges and roof rail. Tighten attaching screws and reinstall previously removed parts.
3. To adjust closed position of lift gate upper edge rearward, remove hinge attaching screws and install emergency spacers between hinge straps and lift gate frame.

LIFT GATE HINGES

1064DF, 2564DF

Each hinge is secured to the roof rail by six (6) screws, and to the lift gate by four (4) screws. The torque rods must be disengaged from the hinges before one or both of the hinges can be removed from the body.

REMOVAL AND INSTALLATION

1. Remove lift gate from body.
2. Remove lift gate opening upper finishing molding and detach headlining from trimsticks along length of gate opening.
3. Remove center and side covers to expose hinge attaching screws "A" in illustration on previous page.
4. With suitable length of pipe as shown in illustration, carefully disengage end of torque rod from support on roof rail. CAUTION: Perform above step carefully. The movement of the tensioned torque rod can cause injury if the end of the rod is disengaged carelessly.
5. Disengage opposite end of rod from lift gate hinge shown in illustration.
6. Remove remaining torque rod as outlined in steps 4 and 5.
7. Scribe location of hinges, then remove hinge attaching screws and hinges.
8. To install, reverse removal procedure. When installing end of torque rod in hinge, be sure to engage hinge link "A" to torque rod as shown in illustration. Lubricate areas indicated by arrows with #630 AA Lubriplate. See lubrication of torque rods in "Body Lubrication" section.

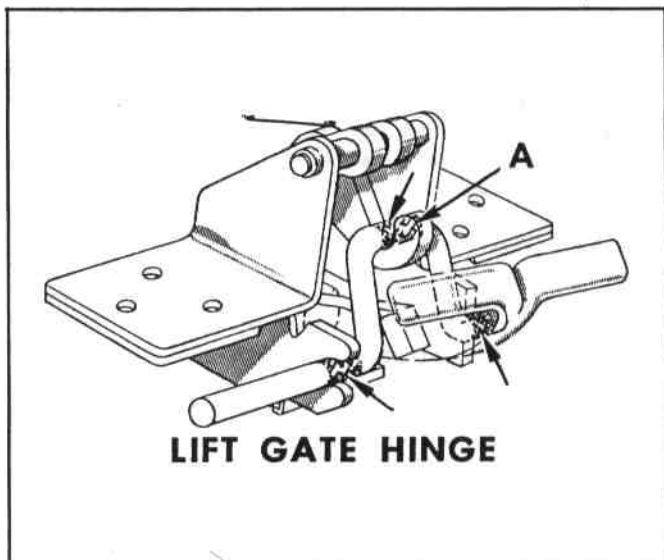

LIFT GATE HINGE

LIFT GATE WINDOW

1064DF, 2564DF

The window is secured in the lift gate by the lift gate outer frame, right and left inner frame, and lower inner frame. These frames are bolted together to form the lift gate frame assembly. The frame must be disassembled in order to remove the glass.

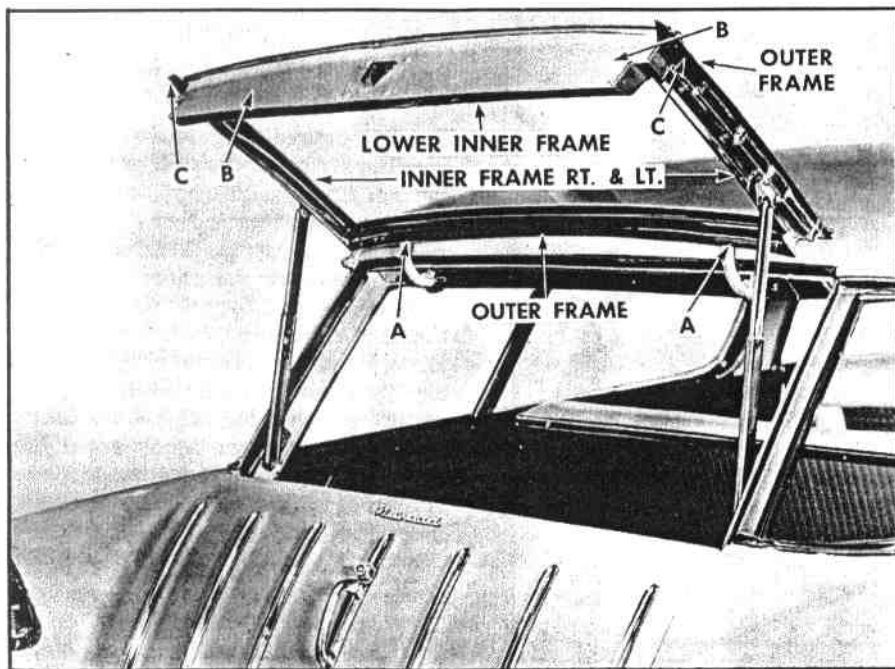

REMOVAL

1. Remove lift gate from hinges and place on covered bench.
2. Remove lift gate inner lower frame finishing covers "B", and lift gate lower corner weatherstrips "C".
3. Remove screws securing frame assembly together, then disassemble side inner frames and lower inner frame from outer frame.
4. With palm of hand, carefully push edge of glass along bottom and sides of outer frame to disengage rubber channel from frame, then pull glass with rubber channel downward to disengage glass from upper portion of outer frame.

INSTALLATION

1. Clean off sealer from around lift gate outer frame and window rubber channel.
2. Assemble rubber channel to glass, then assemble strong cord along outer lip of rubber channel as indicated at one (1), completely around perimeter of glass. Tie and tape ends of cord to bottom center of glass.
3. Apply approved weatherstrip cement between rubber channel and glass, as indicated at two (2), around perimeter of glass.
4. Apply medium-bodied sealer to lift gate outer frame completely around perimeter of opening as indicated at three (3).
5. Position glass and channel assembly to lift gate outer frame by sliding top of assembly into top of frame, then pull string to seat outer lip of rubber channel on top of outer frame around perimeter of opening.
6. Assemble right and left inner frames to outer frame making sure that inner lip of rubber channel is seated on top of frame. Install and tighten attaching screws.
7. Assemble lower inner frame to lift gate outer and side frames making sure that inner lip of rubber channel is seated on top of frame. Install and tighten attaching screws.
8. Install lift gate lower corner weatherstrip with two attaching screws, then reinstall finishing covers.
9. Clean off excess cement and sealer and install lift gate to body.

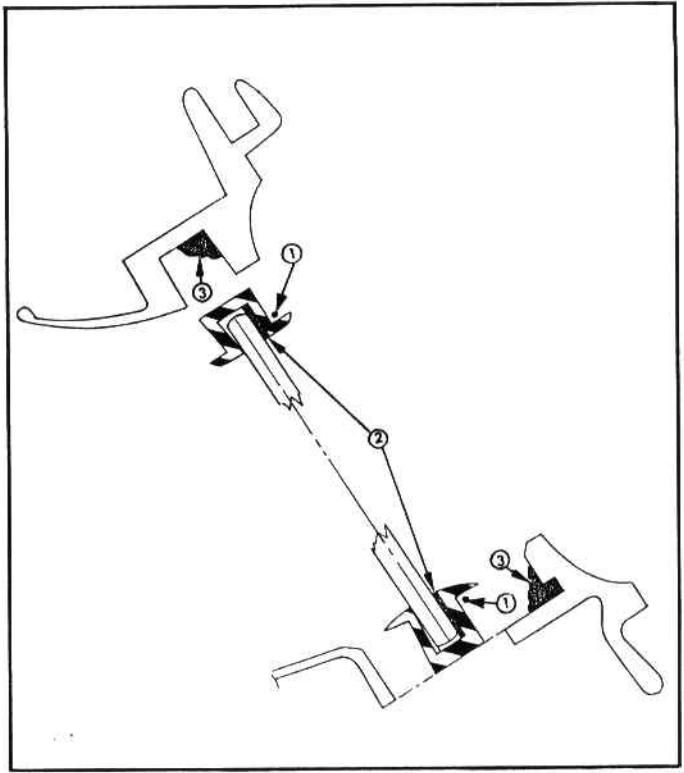

LIFT GATE WEATHERSTRIPS

1064DF, 2564DF

The lift gate weatherstrips consist of a short section of weatherstrip at each lower corner of the lift gate, and of a cemented-on-type weatherstrip which is installed to the body rabbet along the sides and top of the lift gate as indicated by one (1) in Figure "A". In addition a weatherstrip is cemented along the top of the lift gate as indicated at two (2) in Figure "A".

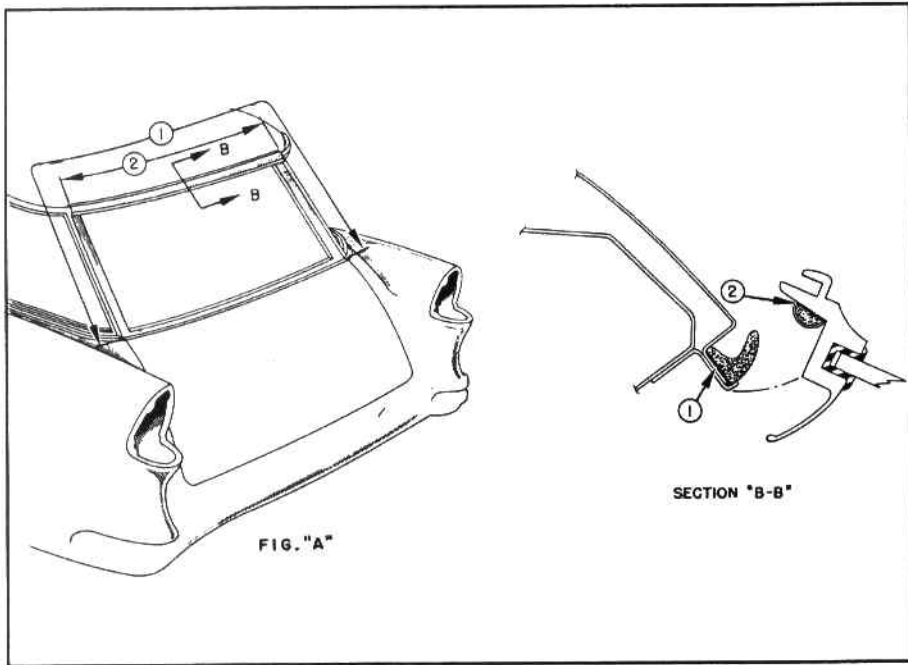

REMOVAL AND INSTALLATION

1. To remove lift gate lower corner weatherstrips indicated at "C" in bottom illustration on previous page, remove finishing covers "B" and two (2) weatherstrip attaching screws.
2. To remove weatherstrip from body or top of lift gate, use suitable tool and carefully break cement bond along length of weatherstrip.
3. To install weatherstrip to body or lift gate, clean off old weatherstrip cement, then apply approved weatherstrip cement following manufacturer's directions to surface indicated at one (1) in Section "B-B".

BACK DOOR ASSEMBLY

1271, 2271

The back door assembly is secured to the back body opening roof rail by two (2) hinges which incorporate torque rods to assist in raising the back door. A telescoping support at each side of the back door locks the back door in an open position. The operation of the back door support is outlined in "Back Door Supports".

REMOVAL AND INSTALLATION

1. Remove back door window garnish molding and window retaining clips.
 2. Remove screws securing supports to back door.
 3. Scribe location of hinges, then with helper supporting door, remove screws indicated at "A" securing door to hinge straps, and remove door from body.
 4. To install, align hinges within scribe marks and reverse removal procedure.
- NOTE: See "Body Lubrication" section for lubrication of hinges.

ADJUSTMENTS

1. To adjust top of back door forward or rearward, remove back window garnish molding and loosen back door attaching screws. Position back door as required, then tighten screws and reinstall garnish molding.
2. To adjust back door sideways in the opening, remove back door opening upper finishing molding on inside of body; loosen hinge attaching screws "B" and adjust door as required, then tighten screws and reinstall finishing molding.
3. For adjustment of back door strikers, see "Tail Gate Lock Strikers".

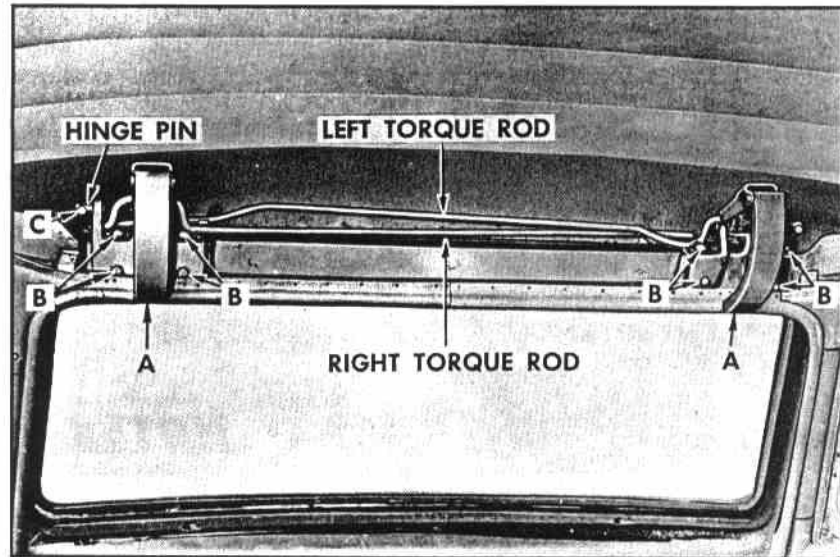

BACK DOOR HINGES

1271, 2271

Each hinge is secured to the body roof rail by four (4) screws, and to the back door by three (3) screws. The torque rods must be disengaged from the hinges before one or both of the hinges can be removed from the body.

REMOVAL AND INSTALLATION

1. Remove back door from hinges.
2. On inside of body, remove back door opening upper finishing molding.
3. Insert suitable length of pipe to end of torque rod at "C". NOTE: Inside diameter of pipe should be approximately 1/2".
4. Carefully pull pipe downward to release tension of torque rod from hinge pin indicated in illustration.
5. While hinge pin is free of torque rod, tap pin toward centerline of body, then slowly position pipe upward until tension in end of torque rod is released. CAUTION:

- Perform steps 4 and 5 carefully. The movement of the tensioned torque rod can cause injury, if the end of the rod is disengaged carelessly.
6. Disengage opposite end of torque rod from left hinge and remove from body.
 7. Remove left torque rod as outlined in steps 3, 4, 5 and 6.
 8. Scribe location of hinges and remove hinge attaching screws.
 9. To install, reverse removal procedure. Lubricate hinges as outlined in "Body Lubrication" section.

BACK DOOR SUPPORTS

1271, 2271

A telescoping support which consists of an inner and outer channel is installed at the left and right sides of the back door. To lock the back door in the open position, turn lock handle to disengage door lock from strikers, then lift door upward until support cams engage in channel slots. To close door from the open position, lift door upward to disengage locking cams from channel slots, then lower door to closed position.

REMOVAL AND INSTALLATION

1. Open door and prop in the open position.
2. Remove screws securing ends of support to door and body, then remove support.
3. To install, reverse removal procedure. For lubrication of back door support, see "Body Lubrication" section.

